

Tender Id: **2024\_CSIR\_201424\_1**

**PROCEEDINGS OF THE PRE-BID CONFERENCE HELD ON 29/07/2024**  
**THROUGH WEBEX TOWARDS SUPPLY OF Stick shaker and pusher.**

The Pre-bid Conference was held and the following T&PC members attended the meeting: -







Sl. No.	Name & Designation		Role
1	Dr. G. Balamurugan	Chief Scientist	Chairman
2	Mr. Ramaswamy Setty J	Chief Scientist	Member
3	Dr. Achuthan C Pankaj	Chief Scientist	Member
4	Mr. Dilip Kumar Sahu	Sr.Technical Officer-3	Member
5	Ms. Rashmi Hundekari	Sr.Principal Scientist	PD-SARAS Member
6	Mr. G Kumaresan	Sr.Principal Scientist	Specialist Member
7	Mr. Narasimha Rao Balla	Sr.Principal Scientist	Specialist Member
8	Mr. Venkatesh K S	Principal Scientist	Specialist Member
9	Mr. Alexander Kale	Principal Scientist	Member - Convener (TSC)
10	COA or his/her representative		Member
11	COFA or his/her representative		Member
12	CoSP or his representative		Convener (T&PC)

The list of Prospective bidders who attended the Pre-bid Conference is as per **Annexure-I**.

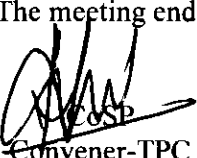
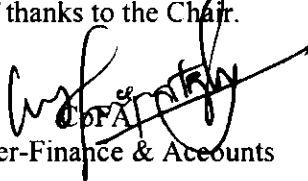
At the outset, the Chairman welcomed all the Members and the representatives of the Bidders and briefed in general the scope of the Project. The Indenting Officer to read out the clarification sought by the bidders and the replied there to as detailed in **Annexure-II (Part A: Technical Clarification and Part B: Commercial Clarification, if any)**.

The representatives present were satisfied with the replies given and it was informed that the corrections / additions / clarifications given, as discussed during the Pre-Bid Conference would be hosted on the CPP portal/website of CSIR-NAL and all prospective bidders are required to take cognizance of the proceedings of the Pre-Bid Conference before formulating and submitting their bids as stipulated in bidding Documents.

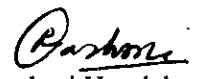
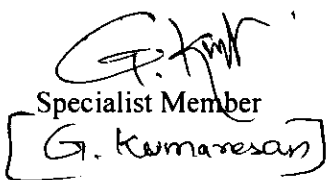
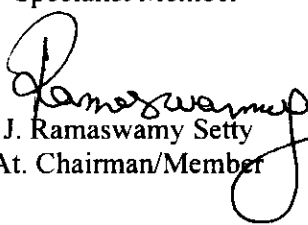
The meeting ended with a vote of thanks to the Chair.

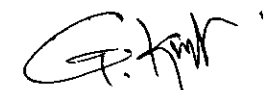
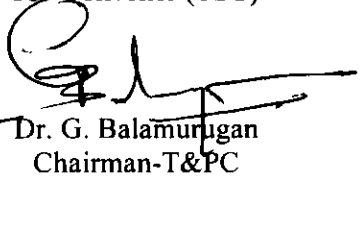
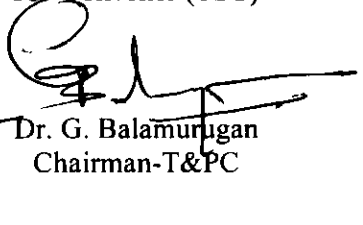
 Convener-TPC	 Member-Finance & Accounts	 Member- Admin
 Dr. Achuthan C Pankaj Member	 Dilip Kumar Sahu Member	 Rashmi Hundekari Member
 Specialist Member [G. Kumaresan]	 Specialist Member J. Ramaswamy Setty At. Chairman/Member	 IO/Convener (TSC)
 Specialist Member	 Chairman-T&PC	 Dr. G. Balamurugan Chairman-T&PC

**NATIONAL AEROSPACE LABORATORIES  
BENGALURU - 560 017**

TENDER ID: 2024\_CSIR\_201424\_1  
TENDER NO.: NAL/PUR/ FMCD/177/23  
DATE & TIME : 29/07/2024, 11 AM  
VENUE: THROUGH WEBEX

ANNEXURE - I

**Pre-Bid Conference for Supply of stall warning and protection system-stick shaker and stick pusher for SARAS MkII aircraft**

Sl. No.	Name of the Firm	Name & Designation of Representative	E-tender Registration (Yes/No)	Email ID
1	Ametek Instruments India Ltd	Mr. Varun Kumar	Yes	<a href="mailto:Varunkumar.vasanth@ametek.com">Varunkumar.vasanth@ametek.com</a>
2	Ametek Instruments India Ltd	Mr. Adity Kumar	Yes	<a href="mailto:Aditya.Kumar@ametek.com">Aditya.Kumar@ametek.com</a>
3				





**CSIR-NATIONAL AEROSPACE LABORATORIES  
BENGALURU - 560 017**

TENDER ID: 2024\_CSIR\_201424\_1  
TENDER NO.: NAL/PUR/ FMCD/177/23  
DATE & TIME : 29/07/2024, 11 AM  
VENUE: THROUGH WEBEX

ANNEXURE - I

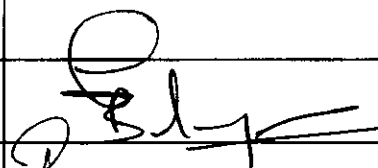
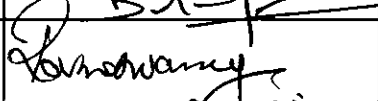
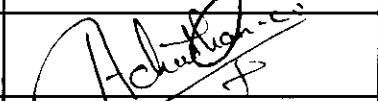
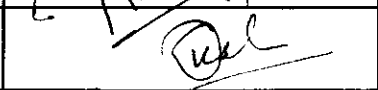
**Pre-Bid Conference for Supply of stall warning and protection system-stick shaker and stick pusher for SARAS MkII aircraft**

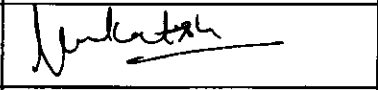
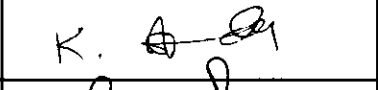
**ATTENDANCE SHEET - T&PC MEMBERS**

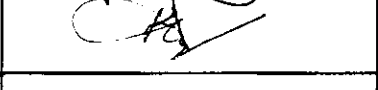
Sl. No.	Name		Signature
1	Dr. G. Balamurugan	Chairman	
2	Mr. J. Ramaswamy Setty	Alt. Chairman/Member	
3	Dr. Achuthan C Pankaj	Member	
4	Mr. Dilip Kumar Sahu	Member	
	Ms. Rashmi Hundekari	PD-SARAS	
5	Mr. G Kumaresan	Specialist-Member	
6	Mr. Narasimha Rao Balla	Specialist-Member	
7	Mr. Venkatesh K S	Specialist-Member	
8	Mr. Alexander Kale	Indentor-Convenor -TSC	
9	COFA or his/her representative	Member	
10	COA or his/her representative	Member	
11	CoSP or his representative	Convenor (T&PC) I.D.	

**CSIR-NATIONAL AEROSPACE LABORATORIES  
BENGALURU  
Annexure-I  
TECHNICAL QUERIES & CLARIFICATION**

**Tender Id** : 2024\_CSIR\_201424\_1

**Tender No.** : NAL/PUR/ FMCD/177/23

**Item Description** : SUPPLY OF DOCUMENTATION FOR STALL WARNING AND PROTECTION SYSTEM STICK SHARKER AND STICK PUSHER

Sl. No.	Query / Clarification Sought	Clarification/Amendment
1	In section 4.4.1, vendor had a query whether the purchaser be present during the testing and inspection procedures at the supplier's premises?	CSIR-NAL clarified that it is not mandatory for the purchaser be present during the testing and inspection procedures at the supplier's premises.
2	In section 4.4.3, the vendor had a query, whether CSIR-NAL has any test setup/facility to do functional/performance Bench Tests?	CSIR-NAL clarified that the required test facility to do functional/performance bench tests is available.
3	In section 4.4.1(8), the vendor had a query whether they will be required to provide all the internal details and drawings or installation and mounting drawings?	CSIR-NAL clarified that the whatever details as required to enable the Purchaser to operate, maintain, adjust and repair all parts of the works as stated in the specifications is required as already specified in section 4.4.1(8)
4	In section 4.2.2.2(a), the vendor had a query regarding the following "The LRU's shall meet the environmental qualifications RTCA DO-160D/G as detailed in Table A2 in section 4.2.3", whether RTCA DO-160G is applicable to new development?	CSIR-NAL clarified that RTCA DO-160G is applicable for new developments.
5	In section 4.2.2.1 the vendor queried about 1. The stick pusher installation and attachment points, 2. Whether stick pusher is linear or rotary output actuator? 3. If it is rotary output, what is the thickness of the cable?	CSIR-NAL has amended the relevant section as follows. 1. Schematic layout of stick pusher is attached. 2. The stick pusher is rotary actuator. Section 4.2.2 is amended as follows "The SWP function shall actuate (without pilot's/co-pilot's intervention) a stick pusher when no action is taken to mitigate the impending stall annunciation. Once actuated, stick pusher shall push the stick control column forward.

The electrical stick-pusher motor shall act as a winch, winding a cable on demand (when activated). One end of the cable is to the motor and the other end of the cable is attached to the aircraft control column. When not activated the motor shall allow free column movements. However, there shall be a minimum cable tension force to avoid slack on the cable. When activated, the stick pusher motor rewinds the cable up to a pre-defined position (corresponding to a pre-defined pitch).

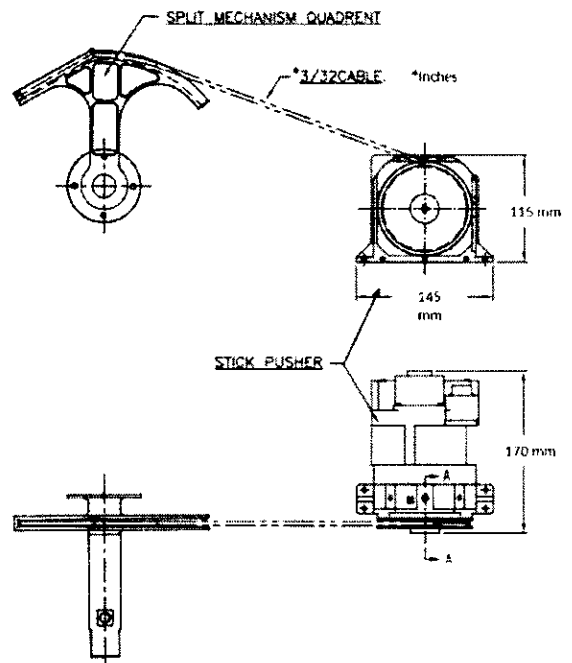

”

3. Section 4.2.2.1 is amended as follows

**4.2.2.1 The specifications of stick pusher**

- Mechanical stroke
  - o The total output cable mechanical stroke must be at least 200 mm.
  - o The output cable mechanical stroke from fully extended position to pre-defined column pitch-up position (when stick-pusher is activated) shall be from 125 mm to 150 mm (should be customizable).
- Drive force and speed
  - o The motor shall be a DC electrical Motor
  - o When activated, the stick-pusher shall be able to retract the cable at a speed of 80 mm/s to 120 mm/s (under a load of 25 N).
  - o The stall load of the stick-pusher shall be 1200 +/- 200 N.
  - o When not activated, the cable traction force shall be between 5 N and 20 N.

		<ul style="list-style-type: none"> <li>• Nominal operating voltage: 28 VDC</li> <li>• The LRU shall receive Motor command and Clutch command from AFCS computer as Discrete inputs.</li> <li>• The LRU shall output Motor actuation feedback and Clutch actuation feedback as Discrete outputs.</li> <li>• Maximum operating current @ 28 VDC: 6 Amps</li> <li>• MTBF shall be as high as possible and in 1000's of hours, in line with current Industry Standards. MTBF preferably shall be greater than 10,000 hours.</li> <li>• <b>The cable diameter is maximum of 3/32 inch.</b></li> <li>• Dimensions and Weight requirements <ul style="list-style-type: none"> <li>o Length : 5 to 10 inch</li> <li>o Width : 5 to 10 inch</li> <li>o Depth : 5 to 10 inch</li> <li>o Weight : less than 4 kg (8.8 lbs) including connectors, brackets.</li> </ul> </li> </ul>
--	--	--

K.   
Signature of Indentor

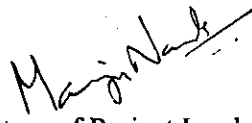
  
Signature of Project Leader

**CSIR-NATIONAL AEROSPACE LABORATORIES  
BENGALURU**

**TECHNICAL QUERIES & CLARIFICATION**

**Tender Id** : 2024\_CSIR\_201424\_1

**Tender No.** : NAL/PUR/FMCD/177/23

**Item Description** : Supply of documentation for stall warning and protection system  
stick shaker and stick pusher

Sl. No.	Query / Clarification Sought	Clarification/Amendment
----- NIL -----		

  
Controller of Stores & Purchase  
For and behalf of CSIR